

PUBLICATION NUMBER: 465-0706
July 1981

(5 yrs)

INSTRUCTION MANUAL
MODEL 505
WAVEFORM ANALYZER

Prepared By:
Autek Systems Corporation
3200 Coronado Drive
Santa Clara, CA 95051
~~(408) 496-0400~~
TWX (910) 339-9328

408
435-2800

619
564-0123

Serial Number _____

Copyright © 1982 by Autek Systems Corporation, Santa Clara, California. Printed in the United States of America. All rights reserved. Contents of this publication may not be reproduced in any form without permission of the copyright owner.

TIME BASE (Cont.)

Calibrator

Output (current source): 10 mA.

Terminating Impedance: 50 ohms.

Period Accuracy: Better than 0.2%.

Frequency: 20 MHz to 2 Hz, crystal controlled, automatically switched to provide identical display on all time/division ranges except range 9.

TRIGGERING

Input Impedance: 50 Ω nominal.

Minimum Trigger Advance: Approximately 50 nS + 2% of full scale time using "I" multipliers.

Mode: AC, DC, + or -; preset for normal triggering.

Sensitivity: (optimum stability)

AC mode, 5 MHz - 100 MHz, 50 mV min.

DC mode, DC - 5 MHz, 200 mV minimum.

Jitter: 50 pS to 50 MHz (optimum trigger stability).

Maximum Input Level: ± 5 volts.

Automatic Unattended Triggering:

Mode: Preset, + or - AC.

Trigger Pulse Width: 1 μ s (optimum of 10 nS).

Trigger Pulse Amplitude: 300 mV to 900 mV.

Trigger Pulse Frequency: to 20 MHz.

VERTICAL

Ranges: 2 mV/div to 100 mV/div. programmed in 2-5-10 sequence using X1 remote sampling probes. Programmed up to 10 V/div using probes with high impedance attenuators.

Digital Accuracy: 1% of reading $\pm 0.5\%$ of F.S. ± 1 count (excluding attenuator errors).

Analog Accuracy: 3% of full scale.

Offset: Programmable to ± 0.9 V in 0.1 V increments, referred to sampling bridge. Manual vernier approximately ± 0.1 V with detented zero.

TABLE 1.1 (Cont.)

LED DISPLAY

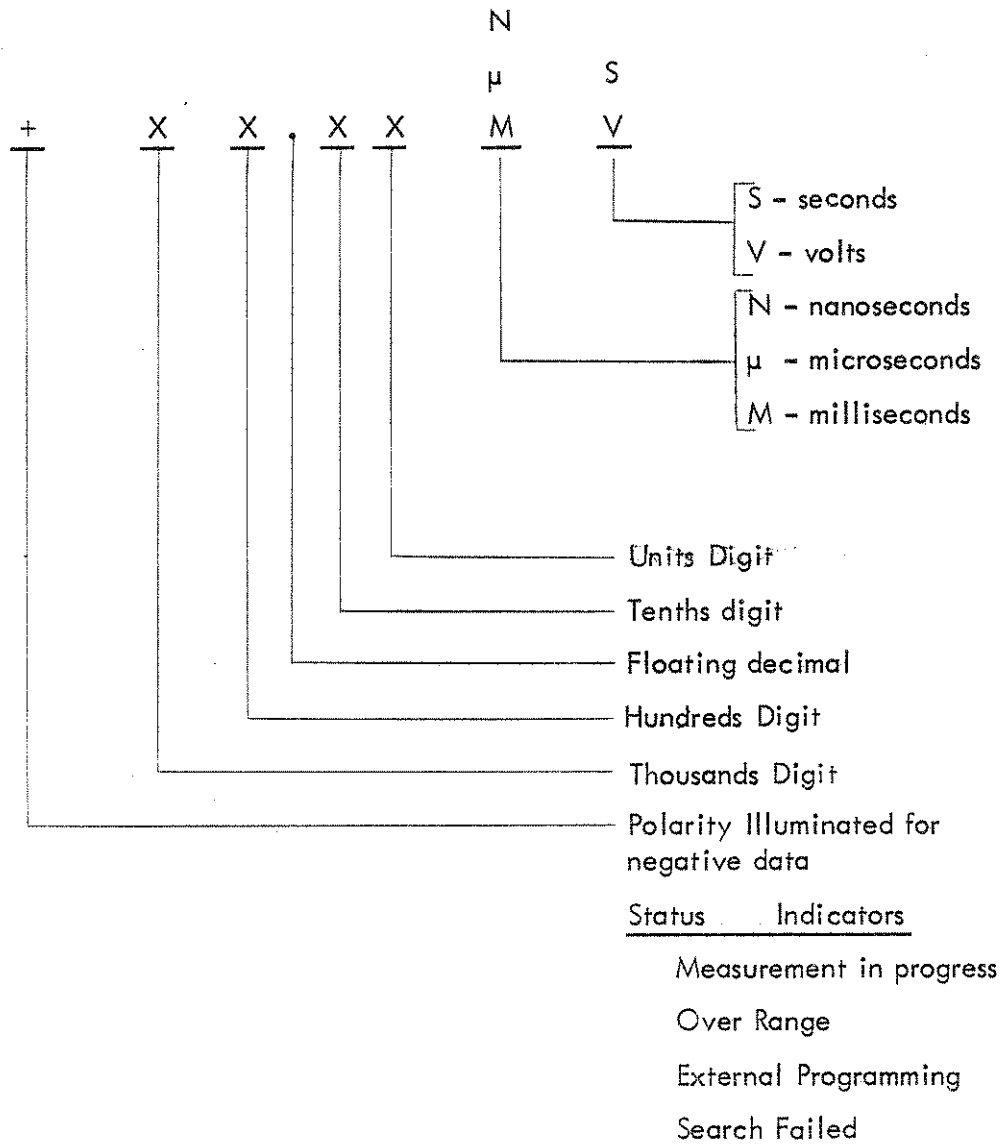

MODEL 505 REAR PANEL CONNECTORS:

A/B Signal
 J107 & J108

Remote sampling probe connectors that accept either Model P20
 50 sampling probe or Model P21 programmable sampling probe.

TABLE 1.1 (Cont.)

ASCII PROGRAM DATA BUSS (J102, J103)	For Remote Control: ASCII bit-parallel, serial-by-character format, TTL low-level true; 25 contact Socket Cannon type DBM25S mates with type DBM25P plug. (J102 deleted in -488 option, J103 is an output for accessories)
TRIGGER INPUT (J104)	Trigger input connector for the Model 505. BNC jack, 50 ohms nominal input impedance.
MIP (J105)	Measurement in progress. TTL high signal while 505 is taking a measurement.
MUX Control (J106)	Parallel control on Autek multiplexers: 37 contact socket DCM37S.
DATA OUTPUT (J109)	Provides serial data output: 37 contact Cannon Socket type DCM37B mates with type DCM37P plug. (J109 Deleted in -488 option)
DATA OUTPUT (J110)	Provides measurement data output on latched parallel BCD lines. TTL high true. Includes 4 digits of data plus overrange flag, search overrange, print command and + sign. 25 contact Socket Cannon type DBM25S mates with type DBM25P plug.
Calibrator Output: J111 provides 10 ma pulse train (into 50Ω impedance). Frequency is automatically set by the time range to provide 500 count period measurement with one multiplier on time ranges 8 through 1.	
IEEE Bus : J112 operates per IEEE 488-1975. (J112 Deleted on -1010 option)	
Power Requirements: 105-125 or 210-250 V, 50-60 Hz, 230 VA. By switch selection. 100V operation by internal wiring modification.	
Dimensions:	
<u>Rack Mount:</u>	8 3/4 in. (22.2 cm) high; 19 in. (48.3 cm) wide; 21 1/4 in. (54.0 cm) deep
Weight:	
<u>Net:</u>	Approx. 40 lb. (22.7 kg)
Shipping:	Approx. 75 lb. (34 kg)

TABLE 1.1 (Cont.)

Options:

-488: IEEE bus per standard 488-1975. The -488 option allows bidirectional transmission of information on the same eight data lines. The 505-488 has capability of talking, listening, serial polling, parallel polling and device trigger. It uses the IEEE 488-1975 subset: AH1, SH1, T6, L4, DT1, PP2.

-1010: Program compatible to EH/AMC 1010. J106 not compatible to EH/AMC 1010 but compatible to Autek accessories. J110 not connector compatible to EH/AMC 1010.

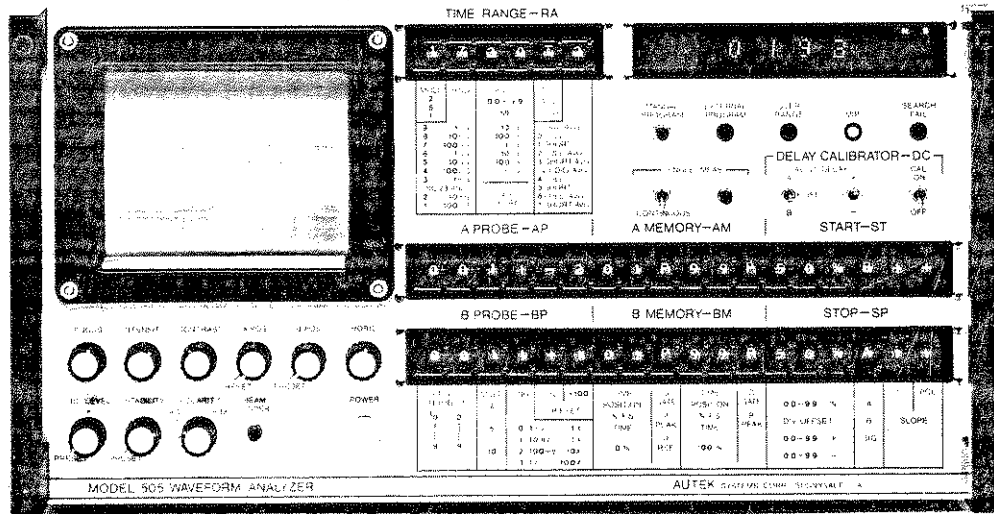

Model 505 Waveform Analyzer Front Panel View

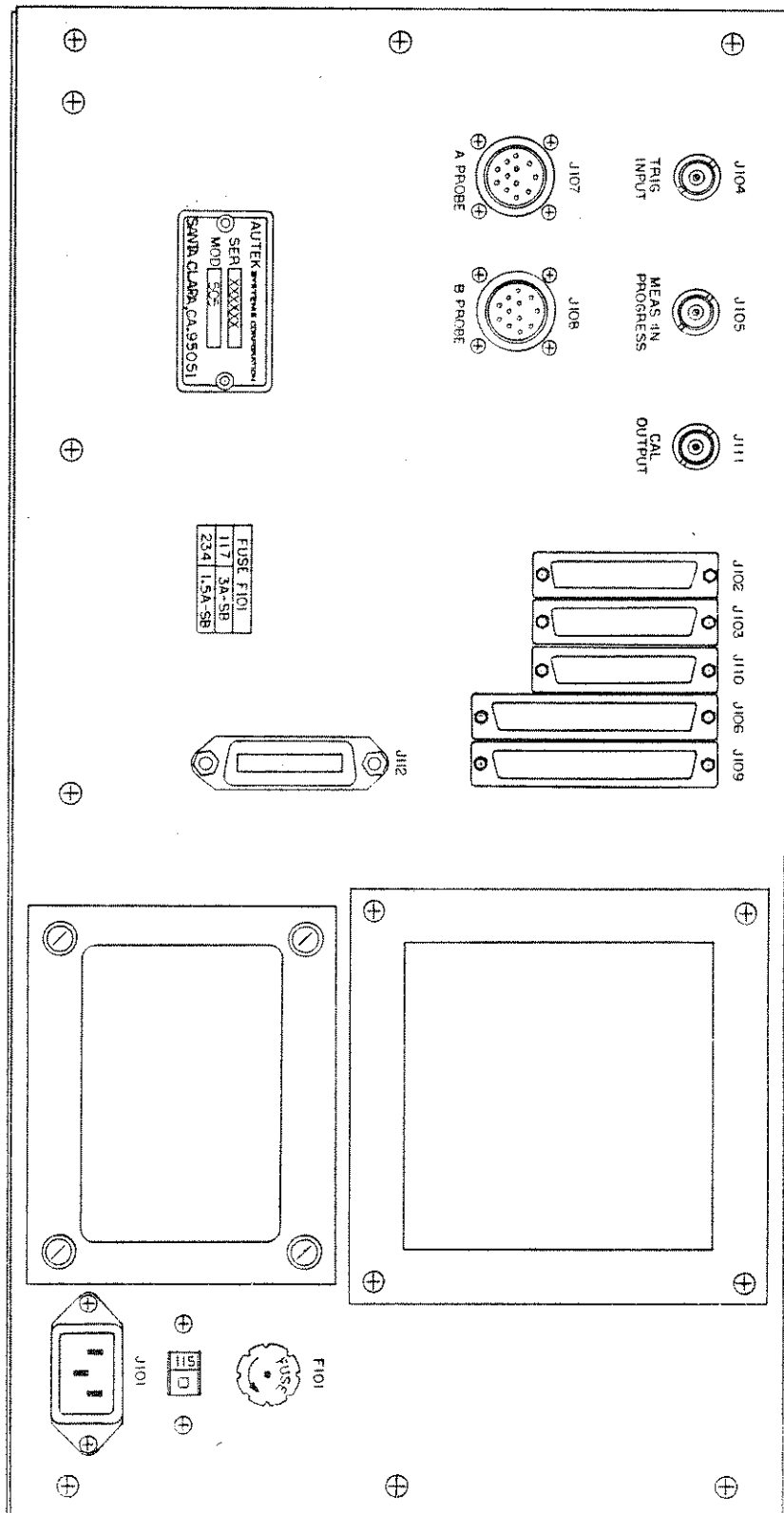

Model 505 Rear Panel View

1.4 APPLICATIONS

The Model 505 Automatic Waveform Analyzer provides great flexibility in automatic testing of repetitive waveform requiring high resolution. Features such as the auto delay, .2, .5, 1 time base multipliers, 10 sweeps averaging and short sweep mode provide state-of-the-art accuracy in an instrument that automatically seeks out the signal and positions it with the proper time reference to the trigger. This is a tremendous asset to valid software preparation.

Both the 50 ohm P20 sampling probe, for high frequency measurements, and the widely used Model P21 probe for monitoring higher impedance circuitry perform very nicely with the Model 505 Waveform Analyzer. These are ruggedized probes of a chassis machined from aluminum bar stock and excellent cable strain relief to protect the advanced sensing circuitry.

The 8 x10 cm CRT with a bright sharp dual-channel display allows operation judgment of waveform qualities that could not easily be quantized. In addition, the front panel controls used in conjunction with the CRT provide an excellent software development tool for the user.

1.4.1 Common System Applications

Some of the common system applications of the Model 505 Automatic Waveform Analyzer include the following:

- 1) Printed Circuit Board testing:

Fast rise time Model P21 high impedance probes with programmable attenuators results in a new dimension in P/C card support technology.

2) Black Box testing:

The Auto-delay feature and the companion delay line-trigger conditioner unit eliminate many of the problems historically associated with automatic testing of black boxes.

3) Semiconductor testing:

The P20 50-ohm probes with less than 350 ps risetime are well suited for testing of high speed semiconductors for rise time, fall time, turn-on delay, etc.

4) MOS Memory Testing:

The high impedance P21 programmable probes adapt the system to dynamic test of waveforms, propagation delays, set-up time, etc., as a compliment to DC and functional logic test.

5) ECM Testing:

Electronic Countermeasures systems often require analysis of detected rf pulse bursts. The ability of the Model 505 to analyze up to nine pulses makes it particularly attractive for this application.

1.4.2 Automatic Test System

The Model 505 Automatic Waveform Analyzer is a versatile measurement center for use in an automatic test system. A system of this type may be a simple paper tape-controlled system with an operator monitoring the digital readout and advancing the tape; the same type of system with GO/NO-GO limit comparators and automatic tape advance; or a computer controlled system with any necessary degree of refinement. Besides the bright LED display of measurement data, the Model 505 outputs data for logging, histogram plotting or other manipulating in parallel BCD format or Serial ASCII or optionally through the IEEE 488 standard interface bus. Refer to OPTIONS Section.

Figure 1.1 shows a block diagram of a typical automatic test system showing computer control of the stimuli, waveform analyzer system and unit under test.

All instruments are computer controlled through either the ASCII interface bus or the IEEE 488 bus. When programmed through the ASCII buss, measurement data is routed in BCD format or Serial ASCII to the computer via a separate bus. However, the IEEE 488 bus is bidirectional with programming, data transfer and all handshaking functions contained within one bus. Figure 1.1 delineates the measurement data buss as a dashed line to indicate that it is not present when the IEEE-488 option is selected.

1.4.3 Auto Delay

Locating the signal may be difficult when using a sampling oscilloscope and this problem is compounded in an automatic test system where the delay program must be entered into computer memory or on a paper tape. For example, it is often necessary to measure the rise time of the output signal from a "black box" when the propagation delay through the device is unknown or variable. A fast time base is needed to make the measurment with resolution and accuracy, however this requires that the delay be accurately programmable to keep the signal on screen.

The Auto Delay feature of the Model 505 meets the requirements for most measurements of this type. Using this mode of operation, the Model 505 seeks the signal and automatically sets the delay to position the signal on the display. The search range is up to 1 screen diameter on the decade ranges (the leading edge must occur within 1 screen diameter of the 2cm mark). A measurement can then be made on an expanded time range for accuracy and resolution, even when the variation in propagation delay through the device under test is large compared to the rise time. When the signal is outside the search range of the Model 505 delay circuit, a visual indication of SEARCH FAIL is displayed on the front panel. Auto delay is not functional in the real time ranges, ranges 1-3. The signal being searched must be at least 2 cm from zero delay and at least 2 cm high for proper operation.

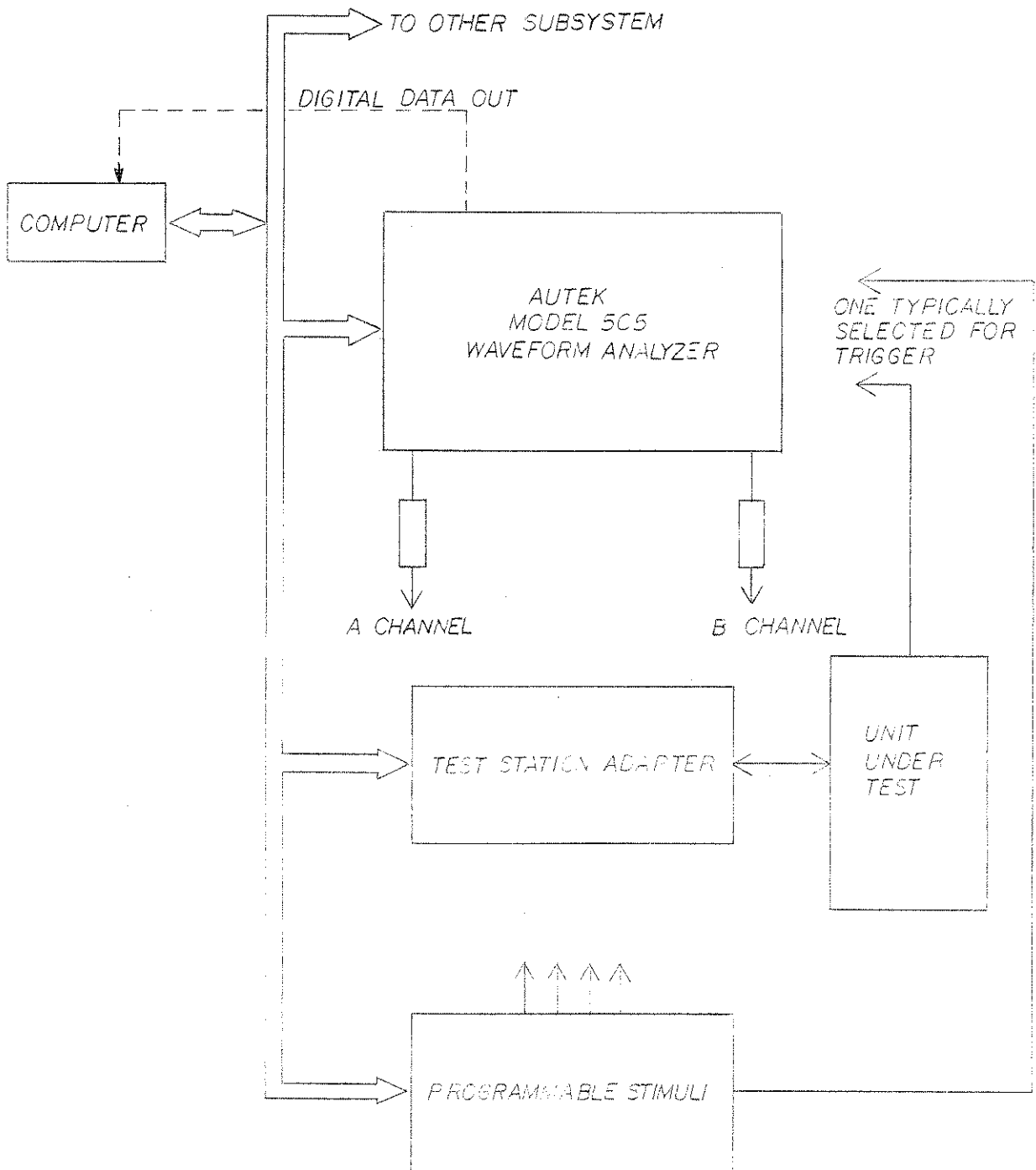

Figure 1-1 Typical System Implementation Using the Model 505

CHAPTER 2 INSTALLATION

2.1 INTRODUCTION

The Model 505 Waveform Analyzer is shipped in an operational condition, and is essentially ready for use as received. This chapter contains unpacking, inspection, and installation information to aid in setting up the instrument for immediate use.

2.2 RECEIVING INSPECTION

As soon as the instrument is received, check the carton for evidence of damage or rough handling. If damage is found, or is suspected, notify the carrier and your Autek Systems representative. Open the shipping container only in their presence.

Use care in removing the instrument from the container. Check immediately for loose or broken controls, bent or broken connectors, and dents or scratches on the panel surfaces. If damage of any nature is found, refer to the warranty instructions in the front of this manual.

All Autek Systems instruments must pass rigid inspection tests before leaving the plant. However, upon receipt, a receiving inspection test should be performed immediately after unpacking to ensure that the instrument is still operational.

2.3 INSTALLATION

2.3.1 Power

The instrument is provided with a 3-conductor power cord which grounds the case when connected through a compatible grounding outlet. If a standard ground outlet is not available, a 3-conductor adapter must be used which provides the necessary grounding connection. Make sure the rear panel Line Voltage Switch is set for the correct power, 115 or 230 V, before connecting the instrument to a power source.

Also, be certain that the proper fuse, F101 is installed (2 amp S.B., 115 Vac; 1 amp S.B., 230 Vac). To change over to 100 volt operation, internal connections to the power transformer must be changed. Transformer connections for various 50-60 Hz power lines are detailed in figure 2.1.

2.3.2 Cooling

The Model 505 design incorporates a cooling fan. Cooling air enters the case through the air filter at the rear panel, passes through the internal assemblies, and exhausts through louvers in the side panels. Care must be exercised not to obstruct the flow of air into or out of the instrument case.

2.4 STORAGE AND RESHIPMENT

Environmental conditions during storage and shipment should be limited to a maximum temperature of 85 degrees centigrade and a minimum temperature of -55 degrees centigrade.

To protect the instrument during shipment or storage, use the best packaging material available. Contact the nearest Autek Systems field office for materials similar to those used in the original factory package. Contract packaging companies are also available to provide dependable custom packaging service on short notice.

1. If at all possible use the original shipping container designed for the instrument. Otherwise, a strong carton (350 lb/sq in. bursting strength) or wooden box should provide adequate protection. (See figure 2-2 for overall dimensions).

2. Wrap the instrument in heavy paper or plastic before placing it in the shipping container.
3. Completely fill the area around the instrument with packing material if the original shipping carton is not used; protect the front panel surfaces with several sheets of cardboard.
4. Seal the package with strong tape or metal bands. Mark FRAGILE-DELICATE INSTRUMENT on the outside of the package.
5. Refer to the warranty in this manual and check with the nearest Autek Systems field office for shipping instructions. In all correspondence, refer to the instrument by full model and serial number.

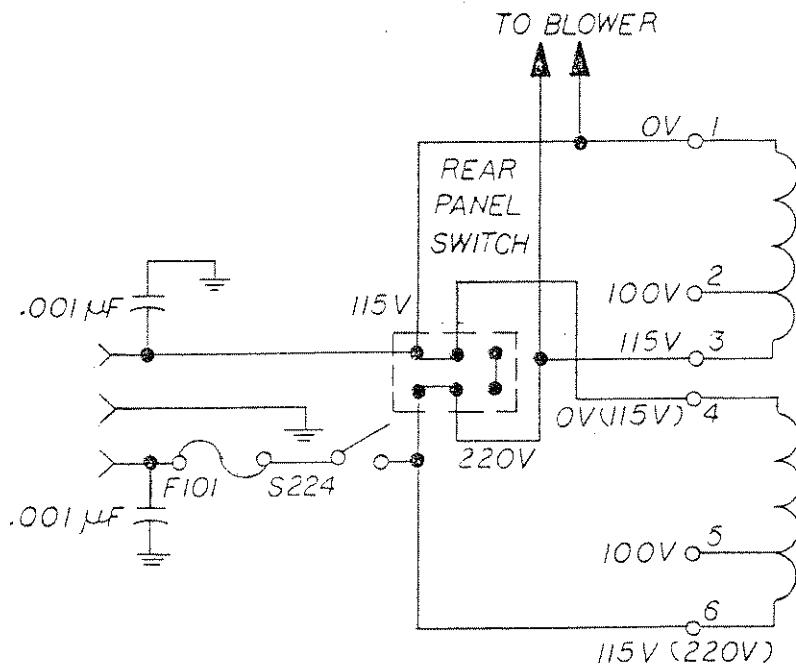

NOTE:
 TRANSFORMER SHOWN
 CONNECTED FOR 115V

FIGURE 2-1 INPUT POWER CONNECTIONS

MODEL 505 OUTLINE

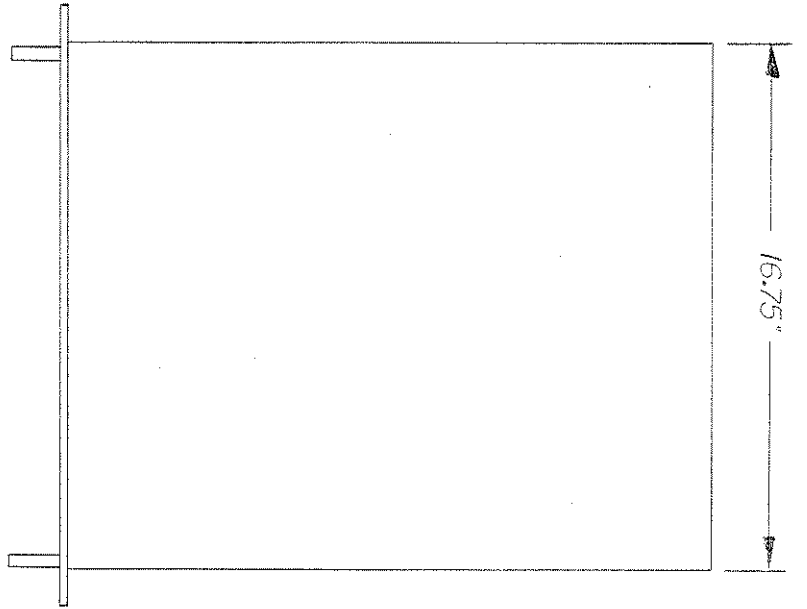
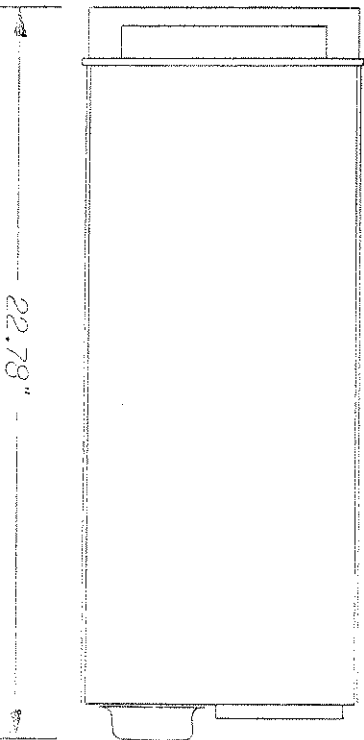
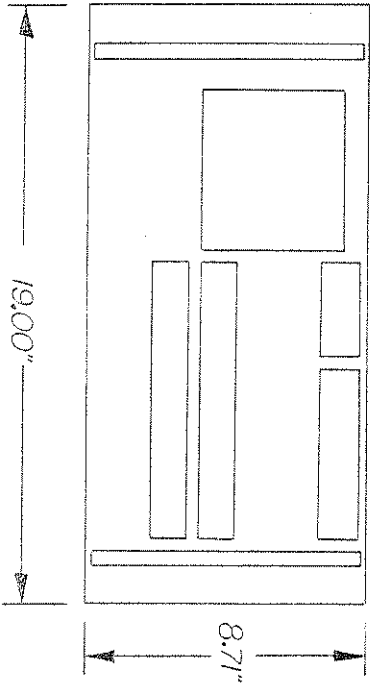
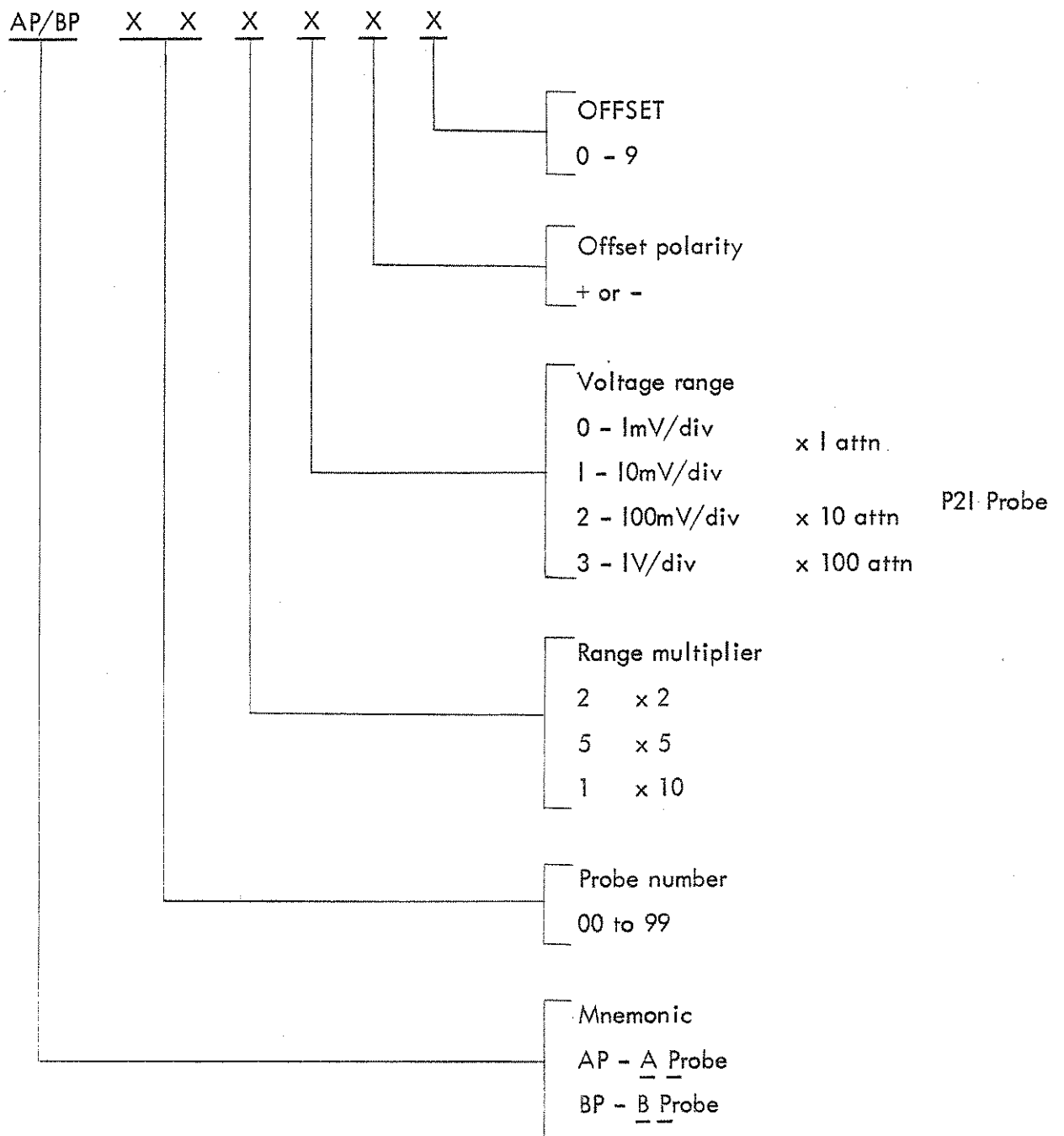
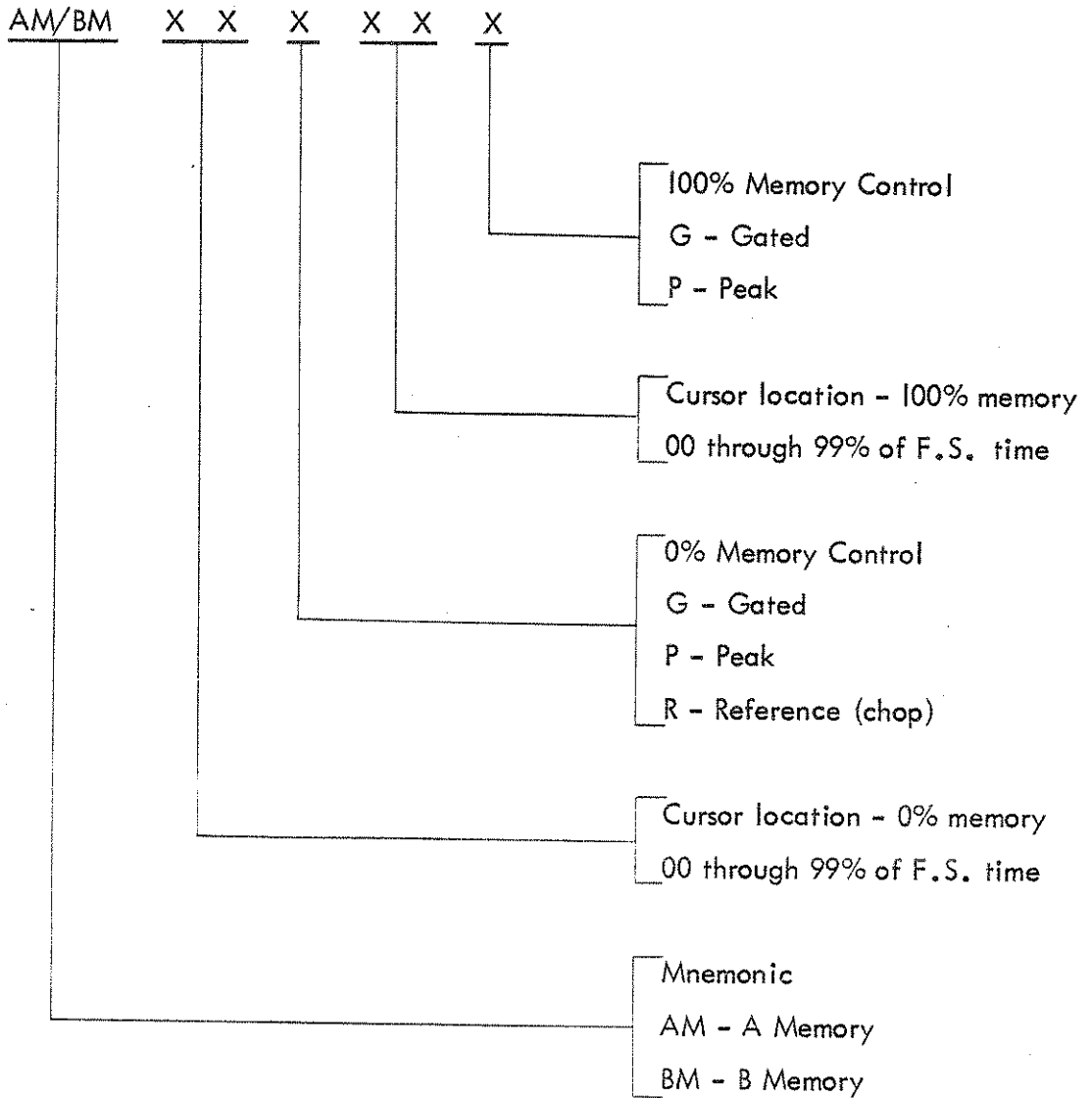

FIGURE 2-2

A/B Probe - selects A/B channel sensitivity, number, and offset position



Memory - Programs the A and B waveform memory to define 0% and 100% levels on the waveform



Each channel has two peak-detecting sample-and-hold waveform memories that are used to define the 0% and 100% levels on the waveforms. The Model 505 makes voltage measurement between the 0% and 100% ^{2 MARKERS} memory levels on either channel. Also, time measurements are started and stopped when the signal passes through programmed thresholds, referred to these two levels.

On each channel two intensified marker dots can be programmed to any point on the sweep, marking the locations of the 0% and 100% memory reference points. When the memories are operated in the gated mode, they are gated on only at these points on the sweep. The signal levels at the respective dot locations are then defined as the 0% and 100% levels of the waveform, even though the signal may make greater excursions somewhere in the sweep.

Both 0% and 100% memories can also be programmed in a peak mode. The memory marker dots then represent the boundaries of a peak search region. The most negative peak in that region becomes the 0% level and the most positive peak the 100% level (the 0% memory is a negative peak detector, while the 100% memory is a positive peak detector).

Start/Stop - determines the START and STOP channels and the point on a waveform where a time measurement starts.

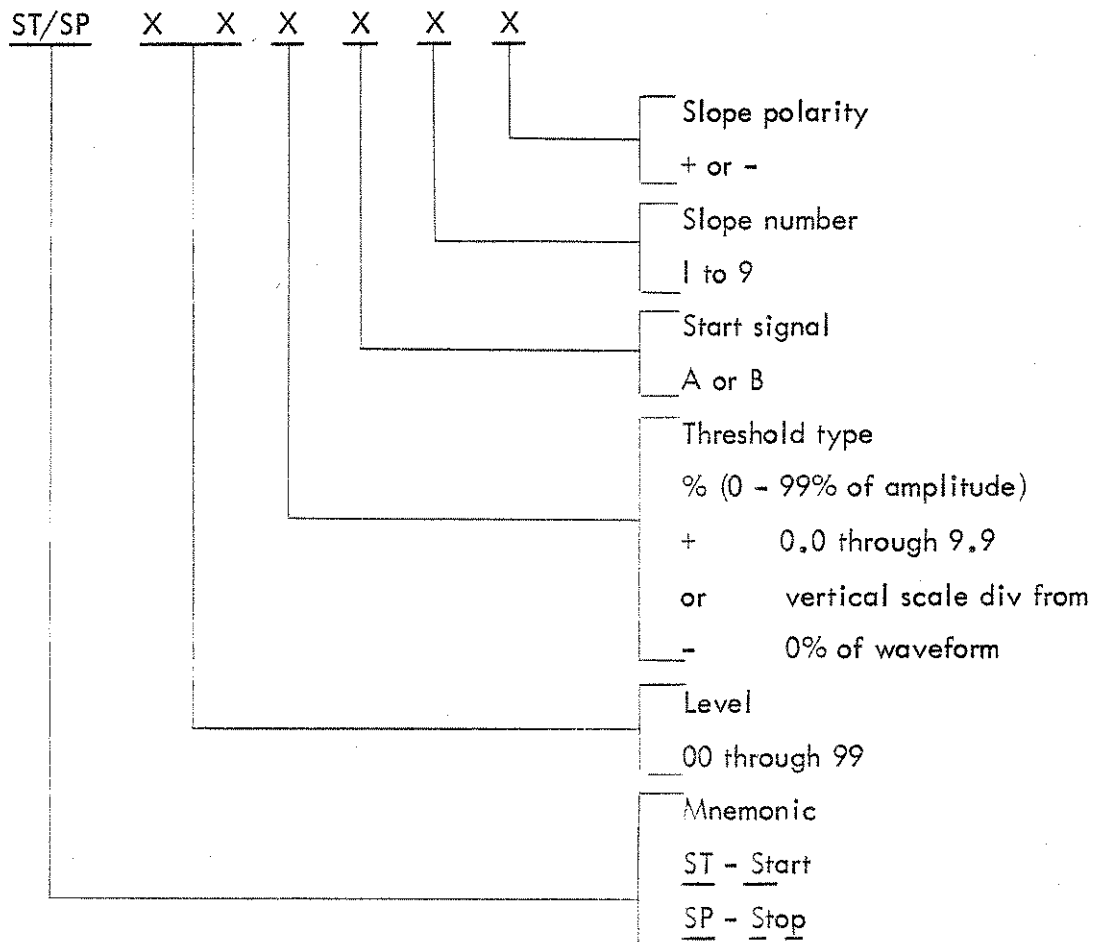

The START and STOP comparators are used in time measurements to determine the measurement start and stop points on one or two waveforms. The DRO gives the time interval between these two points, and this start-stop interval is intensified on the screen. Two identical fields (except for field codes) are used to program the two comparators.

A comparator reference can be either a percentage level on the waveform or a voltage offset. When percentage is used, the waveform memories provide the 0% and 100% voltage levels. The programmed percentage level is derived from a resistive divider connected between the two memories. When offset is programmed, the appropriate 0% memory is the base and a voltage calibrated in scale division (tenths of a centimeter above or below the 0% base) is applied to the comparator reference input.

The comparators can be programmed to start and/or stop a time measurement on either A or B channel, on the 1st through 9th signal transition through the reference level with specified + or - slope.

Delay Mode-Calibrator - controls the on or off state of the calibrator and the delay mode: auto or programmed delay.

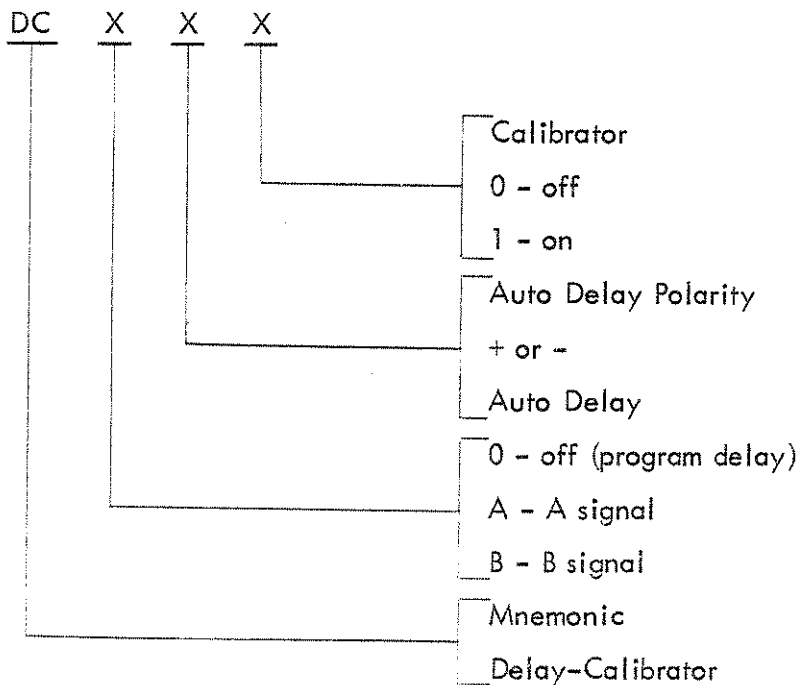

GO Control flag which initiates start of measurement

TABLE 3-1

VERTICAL SENSITIVITY FORMAT

	Sens /div	Mult	Range	F.S. Reading
mV/div	2	2	0	19.98 mV
	5	5		049.8 mV
	10	1		100.0 mV
	20	2	1	199.8 mV
	50	5		0498. mV
	100	1		1000. mV
V/div	.2	2	2	1.998 (-)V
	.5	5		04.98 (-)V
	1	1		10.00 (-)V
	2	2	3	19.98 (-)V
	5	5		049.8 (-)V
	10	1		100.0 (-)V

TABLE 3-2 TIME RANGE FORMAT

	Sens /div	Mult	Range	F.S. Reading 12345	
ns/div	.2	2	9	1.998 ns	
	.5	5		04.98 ns	
	1	1		09.99 ns	
	2	2	2	8	19.98 ns
		5	5		049.8 ns
		10	1		099.9 ns
	20	20	2	7	199.8 ns
		50	5		0498. ns
		100	1		0999. ns
μ s/div	.2	2	6	1.998 μ s	
	.5	5		04.98 μ s	
	1	1		09.99 μ s	
	2	2	2	5	19.98 μ s
		5	5		049.8 μ s
		10	1		099.9 μ s
	20	20	2	4	199.8 μ s
		50	5		0498. μ s
		100	1		0999. μ s
ms/div	.5	5	3	04.98 ms	
	1	1		09.99 ms	
	2	2	2	2	19.98 ms
		5	5		049.8 ms
		10	1		099.9 ms
	20	20	2	1	199.8 ms
		50	5		0498. ms
		100	1		0999. ms

3.3 DIGITAL READOUT

The DRO format is shown in table 1.1. Specifications and more specifically in tables 3-1 and 3-2, which serve as references when programming. Table 3-1 shows the vertical sensitivity format, with the full-scale voltage readout for each sensitivity. Similarly, table 3-2 gives the time base format with the full-scale time readout for each time base.

3.4 REAR PANEL CONNECTORS

All connectors on the Model 505 are located on the rear panel. Figure 3-2 shows the rear panel layout with connector locations and designations. Connector types, designations and functions are given in table 3-3. Pin-outs for these connectors are given in tables 3-4 through 3-6.

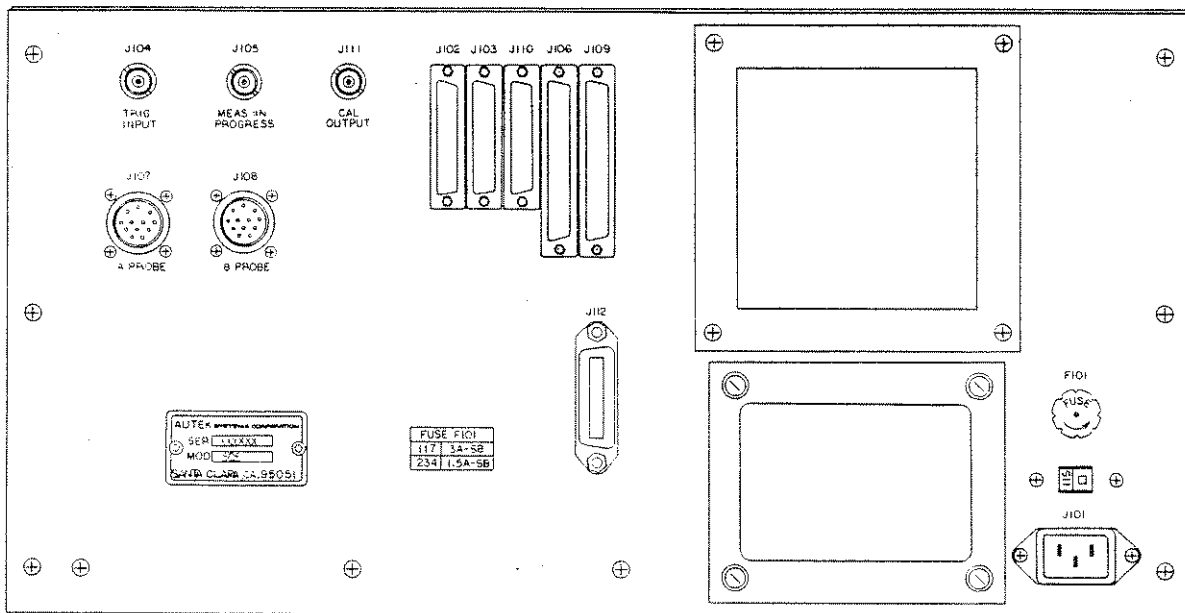

FIGURE 3-2 MODEL 505 REAR PANEL CONNECTORS

TABLE 3-3 MODEL 505 REAR PANEL CONNECTORS

Designation	Name and Type	Function
J101	Power Cord Receptacle (3-wire type with ground)	Connects the main power line to the instrument (100/115/230 Vac, 50-60 Hz).
F101	Fuse Holder (for AG-3 type)	Main power fuse; 3 amp Slo-Blo for 115V, 1 1/2 amp Slo-Blo for 230 V.
J102, 103	ASCII Program Data Bus (Cannon DBM 25S)	Program input for external programming using the conventional ASCII code; bit-parallel, serial-by-character.
J104	Trigger Input	BNC female 50 Ω nominal impedance.
J105	Measurement in Progress	BNC female. TTL high true which 505 is taking a measurement.
J106	Multiplexer Connector	Provide control data for use with Autek multiplexers series 180 (181, 182). 181 is a FET real time multiplexer and the 182 is a sampling multiplexer.
J107 J108	A Signal Probe B Signal Probe	Provide power and attenuator program information for Autek P20 or P21 sampling probes.
J109	Computer Control (Cannon DCM 37S)	Serial data output.

TABLE 3-3 MODEL 505 REAR PANEL CONNECTORS (Cont.)

Designation	Name and Type	Function
J110	Data Output (Cannon DBM 25S)	Parallel output lines provide latched BCD data - 4 digits, also print command and overrange. All will drive at least 5 TTL loads.
J111	Calibration Output BNC	When programmed, the calibrator provides a 10 ma pulse into 50 ohm load whose period is always 500 counts on any decade range from ranges 1 through 8.
J112	IEEE Connector (Amphenol microribbon per IEEE 488-1975)	IEEE 488 option data in/out per IEEE 488-1975 standard.

TABLE 3-4 PROGRAM ASCII DATA BUS (J102,103) (DBM25S)

J102 is an input and J103 is the output for other instruments and is buffered between J102. Do not apply signal into J103. J102 is deleted on the -488 option since I/O is performed through J112. For the -488 option, J103 is an ASCII output to program other AUTEK accessories using ASCII and shares the listener address of the 505. J103 is an output only and not bidirectional.

Pin No.	Signal	J102 FROM	J103 FROM
1	ASCII Bit 1	A10-29	A10- \bar{H}
2	GND		
3	ASCII Bit 2	A10-31	A10- \bar{K}
4	GND		
5	ASCII Bit 3	A10-32	A10- \bar{L}
6	GND		
7	ASCII Bit 4	A10-33	A10- \bar{M}
8	GND		
9	ASCII Bit 5	A10-34	A10- \bar{N}
10	GND		
11	ASCII Bit 6	A10-37	A10- \bar{S}
12	GND		
13	Ready Flag (J102 only)	A16-T	
14	ASCII Bit 7	A10-38	A10- \bar{T}
15	GND		
16	ASCII Bit 8	A10-40	A10- \bar{V}
17	GND		
18	Computer Clock	A16-18	A10- \bar{F}
19	GND		
20	Keyboard Clock (J102only)	A16-U	
21	GND		
22	↓ EXT PROGRAM (Output, J103 only)		A15- \bar{H}

TABLE 3-4 PROGRAM ASCII DATA BUS (J102, J103) (DBM 25S)-Cont.

Pin No.	Signal	J102 FROM
23	+5 V	
24	Computer flag (J102 only) (neg pulse > 100 ns wide)	A16-12
25	GND	

TTL low true < .4V

TABLE 3-5 MULTIPLEXER CONTROL J106 (DCM 37S)

Provide parallel line control of AUTEK multiplexers, Models 181 or 182. The Model 181 is a 10 channel FET (real time) multiplexer which handles Model P32 FET probes and works in conjunction with P20 sampling probe. The Model 182 is a 10 channel sampling multiplexer which can be expanded out to 100 channels with additional 182's. It is used in conjunction with Model P20 or P21 sampling probes.

Pin No.	Signal	FROM
1	↓ A probe 1	A10-H
2	↓ A probe 2	A10-J
3	↓ A probe 4	A10-K
4	↓ A probe 8	A10-L
5	↓ A probe 10	A10-A
6	↓ A probe 20	A10-B
7	↓ A probe 40	A10-C
8	↓ A probe 80	A10-F
9	↓ A sense 2	A1-7
10	↓ A sense 1	A1-6
11	A signal shield	} A1-J7
12	A signal coax	
13	A signal shield	
14	↓ A chopper	A10-27
15	B signal shield	} A1-J8
16	B signal coax	
17	B signal shield	
18	MUX Program	A1-2
19	Ground	A1- \bar{A}
20	↓ B probe 1	A10-U
21	↓ B probe 2	A10-V
22	↓ B probe 4	A10-W
23	↓ B probe 8	A10-X

TABLE 3-5 MULTIPLEXER CONTROL J106 (DCM 37S)-Cont.

Pin No.	Signal	FROM
24	↓ B probe 10	A10-M
25	↓ B probe 20	A10-N
26	↓ B probe 40	A10-P
27	↓ B probe 80	A10-R
28	↓ B sense 2	A1-38
29	↓ B sense 1	A1-37
30		
31		
32		
33	↓ B chopper	A10-26
34		
35		
36		
37	GND	

J107

Table 3-6 A Signal Probe Connector

Pin	Description	From
A	CHOP	A10-27
B	-15	A1-1
C	+5	A1-41
D	+15	A1-43
E	+60	A1-3
F	↓ SENS 1	A1-6
H	↓ SENS 2	A1-7
J	Shield	
K	Coax (Strobe)	A3-J5
L	Shield	
M	Coax (Feedback)	A1-J2
N	Coax (Error Signal)	A1-J3

J108

Table 3-7 B Signal Probe Connector

Pin	Description	From
A	CHOP	A10-26
B	-15	A1-1
C	+5	A1-41
D	+15	A1-43
E	+60	A1-3
F	↓ SENS 1	A1-37
H	↓ SENS 2	A1-38
J	Shield	
K	Coax (Strobe)	A3-J6
L	Shield	
M	Coax (Feedback)	A1-J5
N	Coax (Error Signal)	A1-J6

TABLE 3-8 COMPUTER CONTROL (J109) (DCM 37S)

Data and Control. Rear-panel connector J109 provides data output lines and control lines. The following describes the function of each input and output. This connector is deleted in -488 option.

(1) Data outputs, pin 4 through 9 of J109. These lines provide six parallel ASCII bits with low true logic signals. The data outputs cycle through the eight characters of the digital readout in serial-by-character fashion, starting at the end of a measurement and repeating every 12.3 ms. Data Clock and Data Gate described below allow clocking of the data into peripheral equipment.

(2) Data Clock output, pin 19 of J109. The clock waveform is a 1 μ s negative pulse. The negative-going edge is coincident with the appearance of a new character on the ASCII output lines, and the positive-going edge (appearing in the middle of the character) should be used to clock the data out.

(3) Data Gate output. This is a TTL-level logic signal at pin 28 of J109 that goes low during the time when digital measurement or program characters are being presented on the Data Output lines, and can be used to gate the Data Clock. Normally this signal goes low at the end of a measurement, coincident with the sequence of eight characters is finished. In measurement data mode, Data Gate recurs approximately every 12.3 ms.

Pin No.	Signal	FROM
1	Overrange	A9-U
2	Search Overrange	A4-R
3		
4	DRO Output* 1	A16- \bar{U}
5	DRO Output* 2	A16-39
6	DRO Output* 3	A16- \bar{V}
7	DRO Output* 4	A16-40

TABLE 3-8 COMPUTER CONTROL (J109) (DCM 375)-Cont.

Pin No.	Signal	FROM
8	DRO Output* 5	A16- \bar{X}
9	DRO Output* 6	A16-42
10		
11		
12		
13		
14		
15	↑ Measurement in Progress	A10-39
16		
17		
18	Ground	
19	Data Clock (τ 100 μ s wide)	A16-35
20		
21		
22	Remote Single Measurement (τ input 100 ns min)	A10-4
23		
24		
25	↓ Not Preset	Front Panel
26		
27		
28	Data Gate	A16-38
29		
30		
31		
32		
33		
34		
35	+ 5 V	
36		
37	Ground	

TABLE 3-9 PARALLEL DATA OUTPUT (BCD) J110 (DBM 25S)

Provides latch BCD data output.

Pin No.	Signal	FROM
1	Data bit 1000	A9-F̄
2	Data bit 800	A9-C̄
3	Data bit 200	A9-25
4	Data bit 100	A9-B̄
5	Data bit 400	A9-24
6	Data bit 80	A9-X
7	Data bit 20	A9-20
8	Data bit 10	A9-W
9	Data bit 40	A9-19
10	Data bit 8	A9-T
11	Data bit 2	A9-16
12	Data bit 1	A9-S
13	Polarity ↓ -/ ↑ +	A9-35
14	↓ Overrange	A9-U
15	GND	A9-22
16	↓ Search Overrange	A4-R
17	↑ MIP	A10-39
18	Print Command (JL 1μs)	A9-11
19		
20		
21		
22		
23		
24	Data bit 4	A9-15
25		

TABLE 3-10 IEEE OPTION J112 (Amphenol 24 pin Series57)

Provides data input/output per IEEE 488-1975.

		From
1	DIO 1	A17-4
2	DIO 2	A17-5
3	DIO 3	A17-6
4	DIO 4	A17-7
5	EOI	A17-35
6	DAV	A17-25
7	NRFD	A17-26
8	NDAC	A17-27
9	IFC	A17-32
10	SRQ	A17-31
11	ATN	A17-28
12	Shield	A17-22
13	DIO 5	A17-8
14	DIO 6	A17-9
15	DIO 7	A17-10
16	DIO 8	A17-11
17	REN	A17-33
18-24	Ground	

3.5 INITIAL TURN-ON

The following procedure describes initial turn-on, determines proper operation, and provides operating instructions for the Model 505. For a precise calibration check, refer to Chapter 4.

3.5.1 Preliminary

Before the initial turn-on the instrument should be given a receiving inspection as outlined in Chapter 2. Also inspect the fuse and the setting of the Line Voltage Switch to assure that the instrument is connected for the correct line voltage.

3.5.2 Equipment Setup

- a. The following equipment is needed:
 1. Two sampling probes - either the Model P20 with 50-ohm termination, the Model P21 with programmable attenuators, or one of each. The Model 505 should be used with two probes to properly terminate the sampling circuits.
 2. Cables, adaptors, and attenuators as required.
- b. Connect the equipment as follows:
 1. Connect the Model P20 sampling probes (assumed) with 50-ohm terminations to J107, J108 signal probe connectors on the Model 505.
 2. Connect the Calibrator Output (J111) to A channel probe.

NOTE

The dynamic range of the Model P20 probe is ± 1 volt.

- c. Turn on power, and set the Model 505 controls as follows:
RA1600T0 ($1\mu\text{s}/\text{cm}$), time, full sweep

AP0011 + 0	A signal 100mV/div
BP0011 + 0	B signal 100mV/div
DC 0 + 1	Calibrator on
AM00P99P	(peak-to-peak mode, scanning full sweep)
BM00P99P	(peak-to-peak mode, scanning full sweep)
ST50%A1+	(Start at 50%, first + slope on A channel)
SP50%A2+	(Stop at 50%, 2nd + slope on A channel)

SINGLE/CONT TO CONT

TRIG STABILITY to PRESET

TRIG SELECT to AC+

NOTE: Manual program should be momentarily depressed after turning on power. SINGLE MEAS. should be momentarily depressed after power-on and after any change in Time Range programming.

d. Adjust Model 505 manual controls to secure a normal display.

1. Set the A POS control as necessary to position A trace on screen.
2. Carefully adjust INTENS, FOCUS, CONTRAST, HORIZ and TRIGGER LEVEL controls for a sharp, steady CRT display.
3. The A trace should display a $5 \mu\text{s}$ (approx.) pulse near mid-sweep.

3.5.3 Example Measurements

a. Pulse Period

1. The instrument is now programmed to measure pulse period in the normal mode; the start-stop interval should be intensified.
2. The DRO should read the pulse period at the 50% level; the DRO will indicate $5.00\mu\text{s}$.

b. Avg of 10 Measurements

1. Set the RANGE field to RA1600T2, and momentarily press the SINGLE MEAS. button.
2. The DRO will give the average of 10 readings; the pulse period should read: $5.00\mu\text{s}$.

c. Short Sweep

1. Set the RANGE field to RA1600T1, and momentarily press the SINGLE MEAS. button.
2. The Sweep will terminate at end of measurement. (end of intensified zone)
3. The DRO will read: 5.00 μ s.

d. Average of 10, short sweep

1. Set the RANGE field to RA1600T3, and press SINGLE MEAS.
2. The DRO should be the same, but there will be 10 short measurement sweeps.

e. Width

1. Alter the program as follows:

RA1600T0

ST50%A1+

SP50%A1-

2. The pulse width of the positive pulse from first + edge to first - edge will be read on the DRO.

f. Voltage measurement

1. Alter the program as follows:

RA1600A0 (measure A volts, normal mode)

2. The DRO should read peak-to-peak pulse amplitude (about 500mV).

3. Program the A Memory: AM10G40G (i.e. the 0% marker on the baseline and the 100% marker on the flat pulse top).

4. The DRO will give the gated pulse amplitude between the levels of the marker dots only.

5. Change the program as follows:

RA1600A3 (meas A volts, Avg 10, short sweep)

AM10G40G (Both memories in gated mode)

BM10G40G

6. The DRO will give the average of 10 gated voltage measurements; with no peak memory search.

3.6 TYPICAL MEASUREMENTS

The following are typical voltage and time measurements that can be made with the Model 505. The example measurements serve to familiarize the operation with capabilities of the instrument. Perform the equipment set-up procedures given in paragraph 3.5.2, except turn the Calibrator off and use a pulse generator with settings as follows:

Frequency: 100kHz
Delay: 100ns
Width: 5 μ s
Amplitude: .500 V

Find and display the signal on the appropriate scales. In general the signal must be on-screen to make a measurement (voltage measurements may be made slightly off-screen). For best resolution and accuracy, measurements should always be as near full-scale as possible.

3.6.1 Rise Time Measurement

The rise time of a pulse on channel A can be measured as follows (see figure 3.3)

a. Program the 505 as follows:

RA1900T0 (measure time, normal mode)

AM00P99P (peak-to-peak memory scanning full sweep)

ST10%A1+

SP90%A1+

b. Program the Model 505 and set the pulse generator (especially pulse delay) to place the transition on screen as illustrated in figure 3.3.

c. The DRO will give the 10% to 90% rise time. The start-stop interval (SSI) will be intensified (between the 10% and 90% points).

d. If the pulse has overshoot, ringing or preshoot, the 0% memory should be gated on the baseline and the 100% memory gated on the flat top of the pulse;

e.g., AM15G85G for figure 3.3.

- e. Rise time for a negative transition would be measured by programming ST and SP on the negative slope:

ST90%A1-

SP10%A1-

3.6.2 Pulse Width Measurement

The width of a positive pulse on A channel is measured. Figure 3-4 illustrates the waveform on the display.

- a. Program the Model 505 to position a single pulse on screen as follows:

RA1600T0

AM00P99P

ST 50%A1+

SP 50%A1-

- b. The DRO gives the pulse width at the 50% level.
- c. Programming A memory in a peak-to-peak mode voids the need to know the exact pulse location. However, if the pulse has overshoot or ringing, the 0% and 100% memories should be gated on the baseline and flat pulse top.

3.6.3 Width of Selected Pulse

The width of a selected pulse in a train can be measured by programming the ST/SP comparators for the appropriate transition number from 1 through 9.

Figure 3-5 illustrates the waveform on A channel. The A memory is programmed in a peak-to-peak mode to search out the peaks which define 0% and 100% levels.

- a. Assume that the waveform of figure 3-5 is on screen.
- b. Enter the Model 505 program:

RA1600T0

AM00P99P

ST50%A4+

SP50%A4-

- c. The DRO gives the width of the fourth positive pulse.

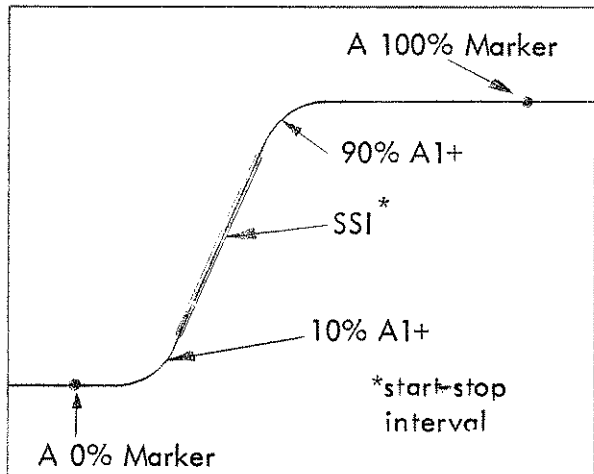

Figure 3-3 Rise Time Measurement

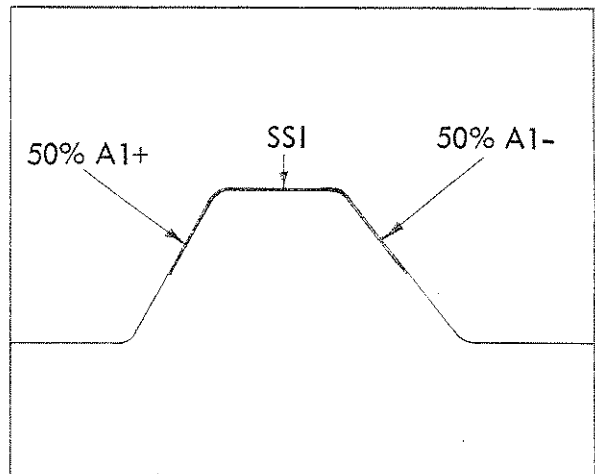

Figure 3-4 Width Measurement

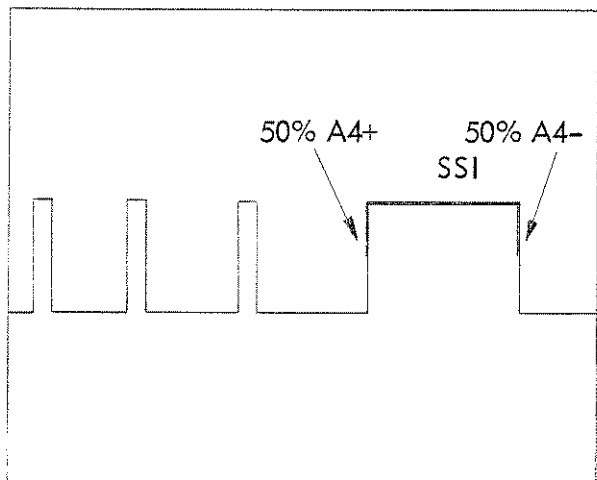

Figure 3-5 Width of Selected Pulse

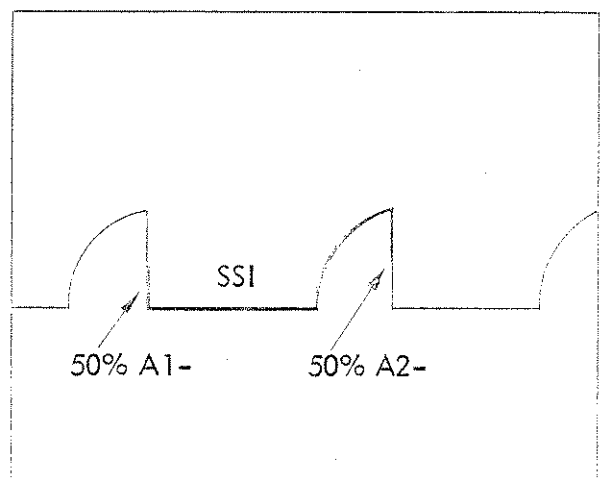

Figure 3-6 Period Measurement

3.6.4 Period Measurement

A period measurement on A channel is illustrated in figure 3-6. For the waveform shown the period is measured using the negative transitions because the faster transition will generally result in a steadier reading.

- a. Program the Model 505 to display at least one full period on A channel as follows:

RA2500T0

AM00P99P

ST50%A1-

SP50%A2-

- b. The DRO reads the period.

3.6.5 Multiple Periods

Period measurement accuracy can frequently be increased by measuring N periods and dividing the result by N. This technique can be used for averaging, or to increase resolution by measuring closer to full scale. A multiple-period measurement on A channel is illustrated in figure 3-7.

- a. Program the Model 505 as follows:

RA1600T0

AM00P99P

ST50%A2+

SP50%A7+

- b. Adjust the pulse generator to obtain a display including a number of periods, such as 10.
- c. The DRO reads the sum of 5 periods.
- d. An average-of-10 measurement mode may also be used to reduce effects of noise; e.g., RA1600T2.

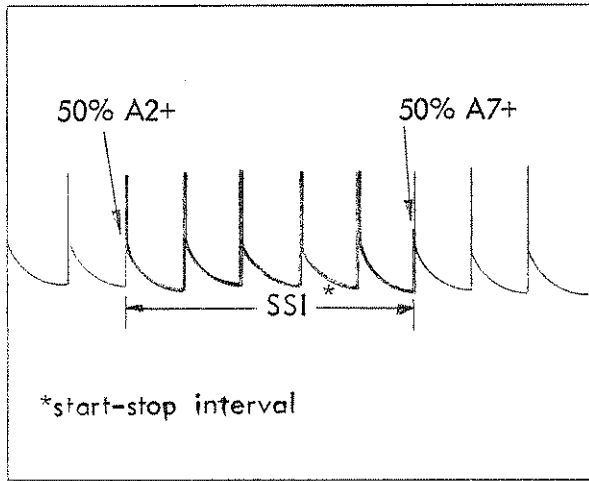

Figure 3-7 Multiple Periods

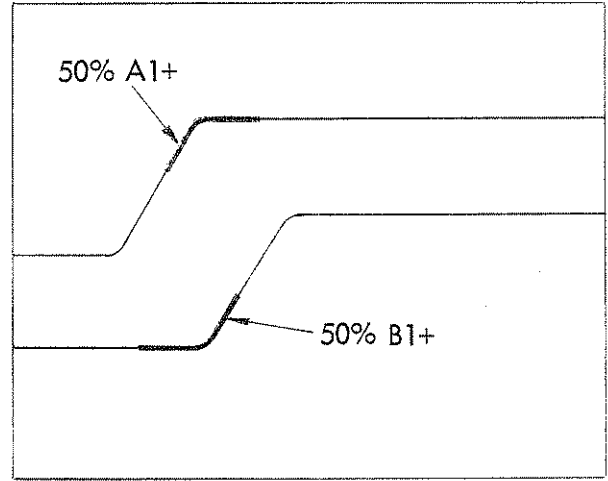

Figure 3-8 Time Difference

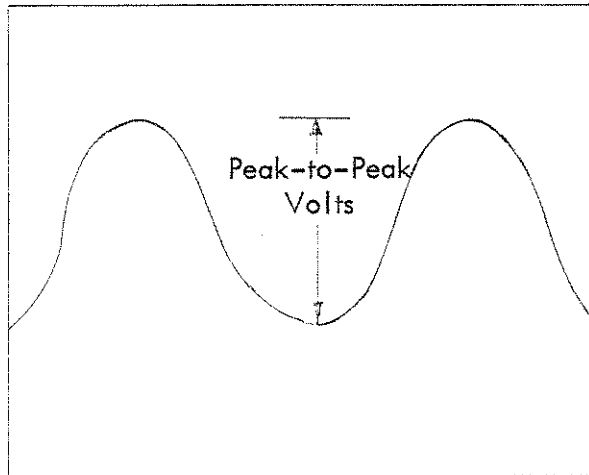

Figure 3-9 Peak Voltage Meas

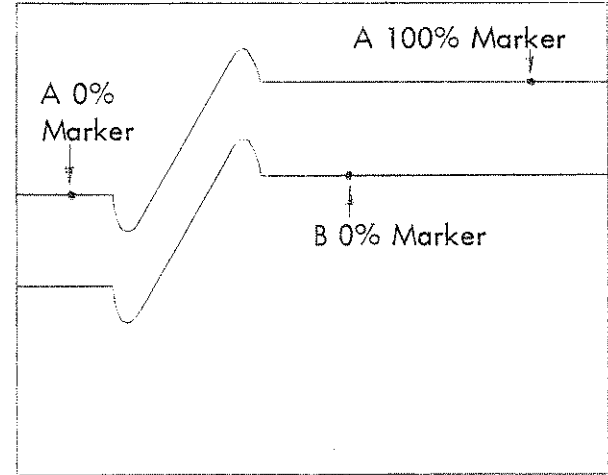

Figure 3-10 Gated Volts and Overshoot

3.6.6 Time Difference

Time difference measurements can be made between points on two waveforms. The close coincidence of sampling points for the Models P21 and P20 Probes allows this measurement to be made with great accuracy. This is useful in comparing coincidence of signals at two ports and in measuring the propagation delay through a device. Figure 3-8 illustrates this measurement for positive transitions on A and B channels.

- a. Program the Model 505 as follows:
RA1800T0
AM00P99P
BM00P99P
ST50%A1+
SP50%B1+
- b. Connect the probes to measure propagation delay through a 4 foot length of coax and adjust the controls so that the signals are displayed as shown in figure 3-8.
- c. The DRO gives the time difference at the 50% levels.
- d. The measurement starts on A signal and stops on B signal. A positive time reading indicates that the transition on A signal occurred first. Likewise, a negative reading would indicate that the transition on B signal had occurred first.

3.6.7 Time to Voltage Threshold

Time measurements can be made with the start and stop points set as voltage levels as well as percentage points on the waveform. For example, if the waveform in figure 3-8 represents the input and output of a TTL gate, the propagation delay at the 1.4 volt threshold might be desired. This is illustrated, assuming that Model P21 probes are used at a sensitivity of 1V/div. The programmed offset voltage is referenced to the 0% memory.

a. Assume that the waveform in figure 3-8 and the Model P21 probes are at 1V/cm. Connect the probes as done in section 3.6.6.

b. Program the Model 505 as follows:

RA1600T0

AP.0012+0

ST14+A1+ (start 1.4 cm or 1.4 V above 0% memory)

SPI4+BI+

c. The DRO gives propagation delay at a level 1.4 volts above ground.

3.6.8 Peak Voltage Measurement

The peak-to-peak voltage of a waveform such as the sine wave shown in figure 3-9 shall be measured using channel A. The peak memory mode searches out the most negative peak between the markers as the 0% level, and the most positive peak as the 100% level. The voltage measurement gives the voltage difference between these two levels.

a. Assume the waveform in figure 3-9, channel A.

b. Program RA1600A0 AM00P99P.

c. The DRO reads the peak-to-peak voltage between the memory markers.

3.6.9 Gated Voltage Measurement

Voltage measurements can be made between specific levels on a waveform by using the memories in the gated mode. Figure 3-10 illustrates a gated voltage measurement on A channel to give pulse amplitude, excluding preshoot and overshoot.

Note: When a gated program is called a dot appears for locating the gated position.

a. Assume the waveform in figure 3-10.

b. Program RA1600A0, AM10G90G; the 0% and 100% memories store the voltage levels at the locations of the marker dots.

c. The DRO gives pulse amplitude from flat base to flat top (between 0% and 100% memory levels).

3.6.10 Overshoot Measurement

A combination of gated and peak memory modes can be used to make selective voltage measurements on a waveform. Figure 3-10 illustrated a waveform measurement of the positive overshoot B channel.

- a. Assume figure 3-10, B channel.
- b. Program RA1800B2 (meas. B volts, Avg-of-10) BM60G00P
- c. The 0% memory is gated to define the flat pulse top 6.0 cm down the sweep as the 0% level.
- d. The 100% memory scans the waveform from 0.0 cm to 6.0 cm, setting the most positive peak in that region as the 100% level.
- e. The DRO reads the height of the positive overshoot above the flat pulse top. The vertical sensitivity may be increased for greater resolution.
- f. The negative preshoot could be measured as given in step e by programming BM60P10G.

3.6.11 Auto Delay

The Auto Delay is used to automatically find and position a signal on the screen. Requirements for auto delay to function properly are: the signal must be at least 2 cm high on the CRT and the position of the signal must be greater than 2 cm after the beginning of the sweep. The Delay/Calibrator field can be set to search for the leading edge of either a positive or a negative pulse (with respect to baseline) on either A or B channel and position it on the CRT such that the point 2 cm after the beginning of the sweep is approximately 1.5 cm above (or below) the baseline, as shown in figure 3-11. The baseline is defined as the voltage level present at zero-delay time. Because of this baseline, the "chop" mode (AMXXRXXX or BMXXRXXX) should not be used with Auto Delay.

- a. Set equipment as follows:
 - Pulse Generator: Frequency 100kHz approx
 - Delay 1 μ s approx
 - Width 1 μ s approx
 - Amplitude 500 mV positive
 - Risetime 1-10 ns
 - Signal to Probe A

505 Program: AP0012+0
RA1700T0
DCA+0 (Auto Delay, Calibrator off)
CONTINUOUS MEASUREMENT MODE

- b. If the pulse was within the search range of the Model 505, the leading edge should have indexed near the left edge of the screen as shown in figure 3-11.
- c. If the search for the signal failed due to the pulse being located outside the search range of the Model 505, the SEARCH FAIL light will flash. In this case, reduce the pulse generator delay slowly until the signal is indexed as in figure 3-11 and the light will go off. The Model 505 continues to search repeatedly, so that the pulse generator delay can be altered until the search succeeds.
- e. Invert the pulse, if the pulse generator has this function. The search will fail since the Model 505 is searching for a positive pulse.
- f. Reset the DC field to search for a negative pulse on A channel (DCA-0). The Model 505 should find the leading (falling) edge and position it as before.
- g. Auto Delay is not functional on the real time ranges (1-3).

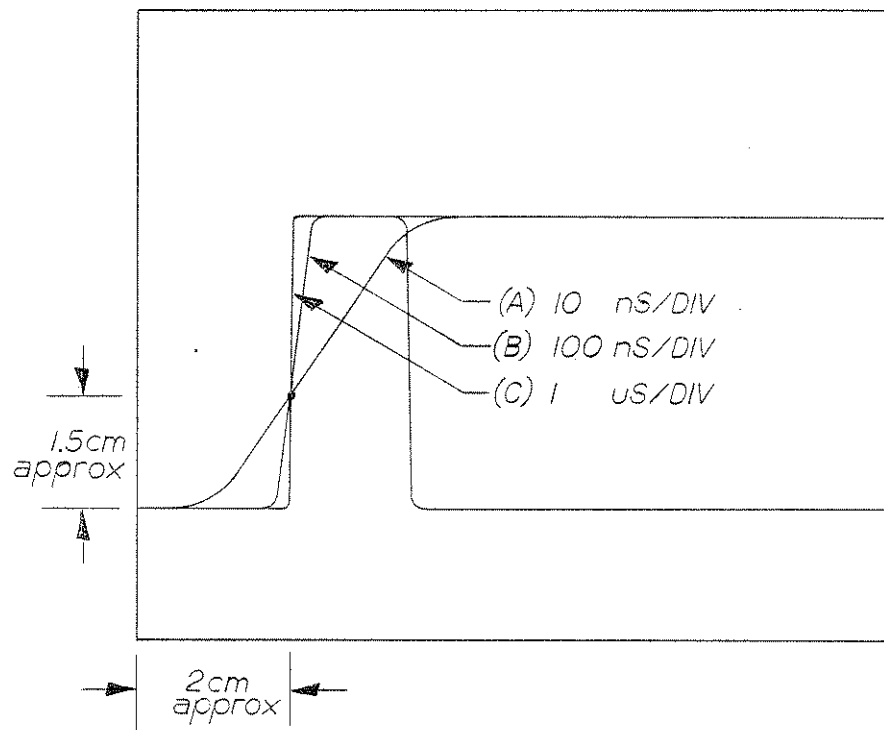

Figure 3.11 Auto Delay Indexing - Positive Pulse

3.7 REMOTE PROGRAMMING - MANUAL PROGRAMMING

When powered on, the 505 is initiated into remote control as indicated by the front panel "ext. prog." led. To obtain manual front panel control, depress the "Manual Program" button. Front panel controls are enabled when the "external program" led is extinguished. The instrument automatically returns to external program when any valid field code or program command is received by the 505. During manual program, any external program information is lost in the program registers and will retain the manual program information when the instrument returns to external program mode until altered by external programming. The recognized commands are GO, RA, AP, BP, AM, BM, ST, SP, computer flag (J102 pin 24) or device trigger (IEEE 488, GET).

3.7.1 REMOTE PROGRAMMING

Remote programming allows the Model 505 to be programmed from an external source such as a computer, paper tape reader or keyboard. This is useful in automatic test systems which perform waveform analysis. In a fully automatic system a computer can program the Model 505 and command a measurement on a waveform. The measurement results are sent back to the computer or recorder for comparison with limits in GO/NO-GO testing or for developing histograms etc. In this type of system, measurements can be made at very high rates.

Remote program interfacing with the Model 505 is accomplished through the Program Data Bus J102. The ASCII code and interface requirements for the 505 are discussed below.

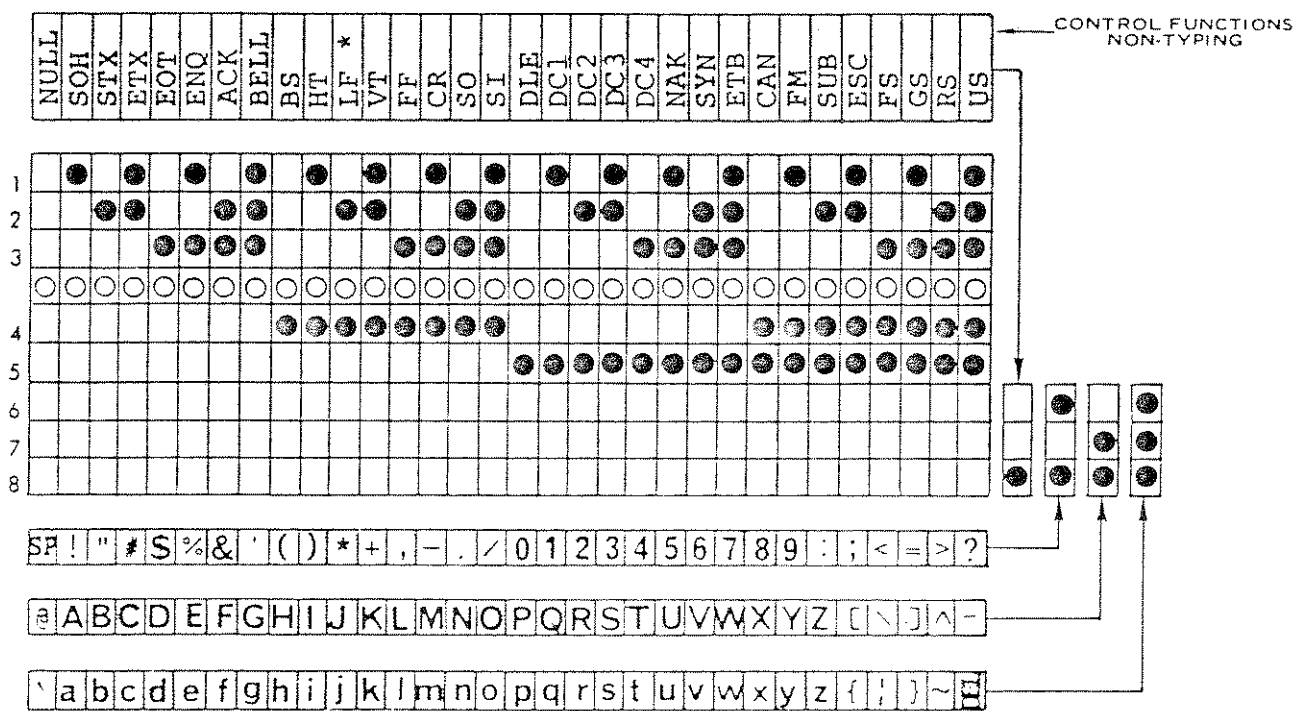

* WHERE APPROPRIATE, THIS CHARACTER MAY HAVE THE MEANING "NEW LINE" (NL).
 ● MARK TO OBTAIN EVEN PARITY. THE CHARACTERS AND FUNCTIONS SHOWN WITH SHADED BACKGROUNDS HAVE 8th BIT MARKING.
 UPON RECEIVING CODE COMBINATIONS FOR ` THROUGH ~, MONOCASE EQUIPMENT SUCH AS MODELS 33 AND 35, PRINT RESPECTIVE CHARACTERS ● THROUGH ^.

FIGURE 3-12 ASCII CODE CHART

3.7.2 The ASCII Code

Program data to the Model 505 is sent in bit-parallel, serial-by-character format on 6 data lines. ASCII code is used for the program data transmission (American Standard Code for Information Interchange). The ASCII input lines to the Model 505 are TTL low-true. The ASCII code is shown in figure 3-11, in which the dots signify the Low or "1" state.

3.7.3 Program ASCII Data Bus (J102,103)

Remote programming from an ASCII source is applied to J102 on 7 data lines in bit-parallel, serial-by-character format. An additional line is used for the ASCII clock, which must occur within the clean region of the data bits in case there is contact bounce. The minimum ASCII clock width is 1.5 μ s.

Table 3.4 details the pin connections for J102,103. All lines are TTL low-true, with 0 to +0.4V representing the low state and +2.4V to +5.0V representing the high state. Each data line represents one TTL load; i.e., the data source must be capable of sinking approximately 2 mA in the low state.

In remote state the thumbwheel switches are disabled and the content of the program registers controls the instrument. When manual programming, the program registers retain the last program entered from the front panel and the instrument reverts to this program reverted back to remote state. An EXT PROG light on the Model 505 front panel read out indicates the program state. A low-true computer flag on J109 pin 22 can be used to command a measurement. This has the same effect as the GO command in ASCII characters and the SINGLE MEAS button on the front panel, but responds faster.

3.7.4 Program Format

Programmable functions of the Model 505 are controlled by eight program registers, one containing a field of 3 characters, and the rest 6 characters.

Each of these eight fields controls a related group of functions: Range, A Memory, B Memory, Start Comparator, Stop Comparator, A Probe, B Probe, Delay Mode, and Calibrator. In addition, each register has its own address or mnemonic field code consisting of two alpha characters. The program register addresses or field codes are RA, AP, BP, AM, BM, ST, SP, and DC.

The instrument also decodes the field code GO, which can be used to command a measurement. A program word to control any of the fields consists of the two-character field code followed by the appropriate program data characters. For example, letting the actual program data be represented by X's, a complete program in addition to the measurement command for the Model 505 should be as follows:

```
RAXXXXXX
APXXXXXX
BPXXXXXX
AMXXXXXX
BMXXXXXX
STXXXXXX
SPXXXXXX
DCXXXXXX
GO
```

The program data format for each word or field is identical to that given for the thumbwheel switches. By addressing the program registers with the appropriate field codes, a program manually set by the thumbwheel switches can be remotely entered from an ASCII keyboard by copying the settings on the bank of switches.

Any program word (or an entire program) is entered without spaces or punctuation. The words may be programmed in any sequence, provided only that each field code is followed by the appropriate valid program data. Any field may be edited at any time reentering the complete word with desired changes.

3.8.1 Operation of IEEE 488-1975 (Option -488)

The -488 option allows the Model 505 to operate in conformance with IEEE standard 488-1975. The IEEE bus is a byte serial, bit parallel interface system.

The basic guidelines for the bus are:

1. No more than 15 devices can be interconnected by a single contiguous bus.
2. Total transmission length is not to exceed 20 meters, or 2 meters times the number of devices, whichever is less.
3. Data rate through any signal line must be less than, or equal to, 1 Megabit/second.
4. All data exchange is to be digital (as opposed to analog).

The 488-1975 system is structured with 16 transmission lines. They consist of:

1. 8 data bus lines, permitting transmission of ASCII characters. Data is asynchronous and generally bidirectional.
2. 3 data byte transfer control lines (handshake).
3. 5 general interface management signal lines.

These lines may employ either open-collector (not open-collector in an absolute sense due to the termination networks on the bus) or three-state driver elements with certain constraints on the SRQ, NRFD, DIO1-8 and NDAC lines.

3.8.2 Bus Line Callouts

The following are the 16 lines defined in the 488 bus and their definitions:

DIO1-DIO8 Data Input/Output -- These are the message lines for carrying data in a bit-parallel, byte-serial form. Data is asynchronous and generally bidirectional. These lines carry either data or address information, depending on the condition of the ATN line.

DAV (Data Valid) -- One of the three Handshake lines used to indicate availability and validity of information on the DIO lines. DAV indicates to the acceptor(s) that data is available on the DIO lines.

NRFD (Not Ready for Data) -- Another Handshake line used to indicate that all devices are or are not ready to accept data.

NDAC (Not Data Accepted) -- The final Handshake line used to indicate the acceptance of data by all devices.

ATN (Attention) -- One of five bus management lines used to specify how data on the data lines are to be interpreted and which devices must respond to the data.

When ATN is true the DIO1-8 lines carry addresses or commands. When false they carry data. (Controller driven.)

IFC (Interface Clear) -- A bus management line which is used to place the interface system in a known quiescent state. All interconnected devices contain some portions of the interface system. IFC puts talkers, listeners into their idle states. (Controller driven.)

SRQ (Service Request) -- A bus management line used by a device to indicate a need for service and to request an interrupt of the current events sequence.

REN (Remote Enable) -- This management line in conjunction with other messages selects between two alternate sources of device programming data. (Example: front panel control or interface control.) (Controller driven.)

EOI (End Or Identify) -- The final management line used to indicate the end of multiple byte transfer sequences or with ATN to perform a parallel polling sequence.

The 488 bus works on the principle of the 3 wire handshake* and operates according to the follow flow chart.

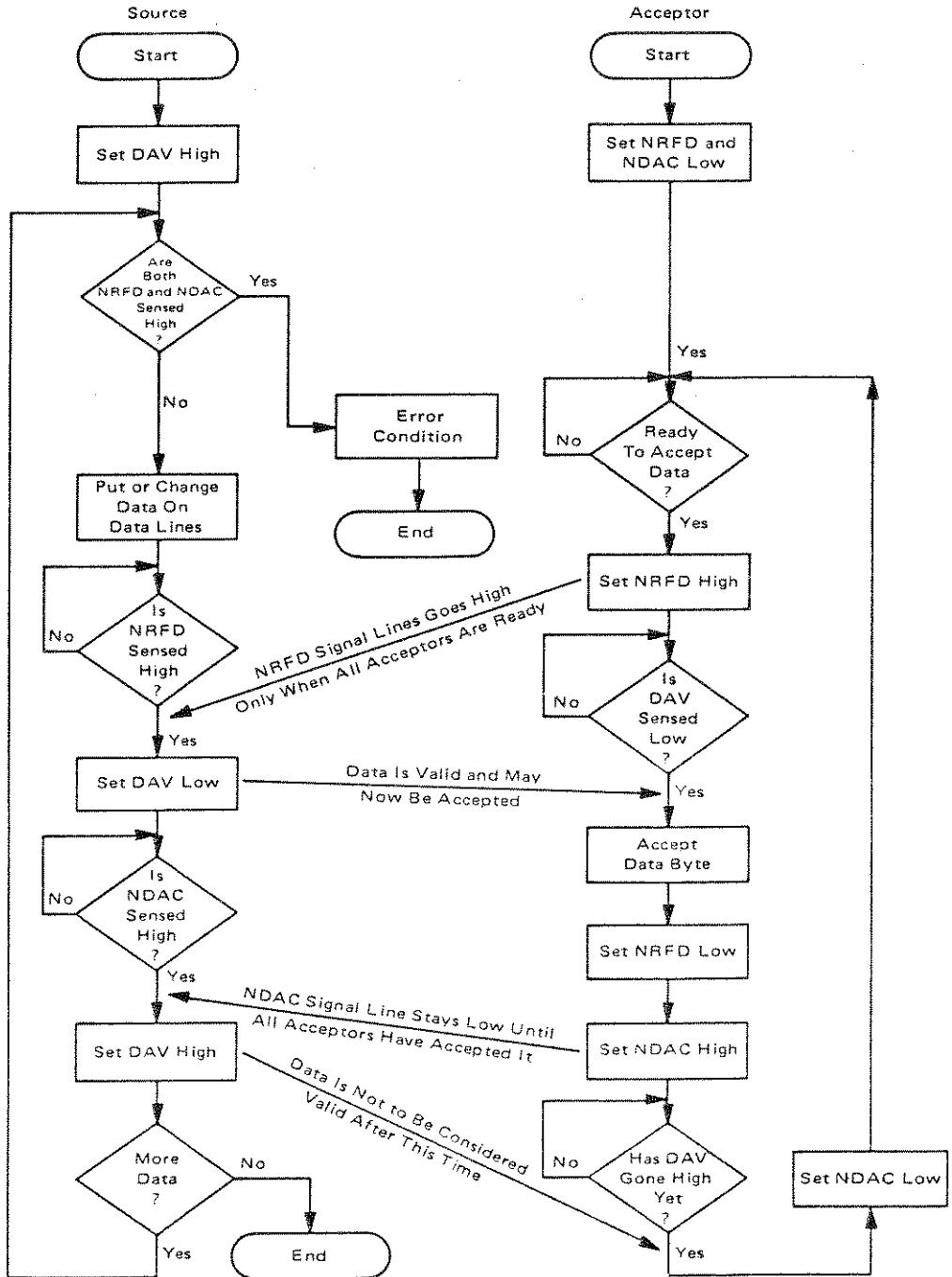

Flow diagram outlines sequence of events during transfer of data byte. More than one listener at a time can accept data because of logical-AND connection of NRFD and NDAC lines.

* process patented by Hewlett Packard

TABLE 3.11-- Connector Pin Assignments

Contact	Signal Line	Contact	Signal Line
1	DIO1	13	DIO5
2	DIO2	14	DIO6
3	DIO3	15	DIO7
4	DIO4	16	DIO8
5	EOI	17	REN
6	DAV	18	Gnd, (6)
7	NRFD	19	Gnd, (7)
8	NDAC	20	Gnd, (8)
9	IFC	21	Gnd, (9)
10	SRQ	22	Gnd, (10)
11	ATN	23	Gnd, (11)
12	SHIELD	24	Gnd, LOGIC

NOTE: Gnd, (n) refers to the signal ground return of the referenced contact.

The IEEE bus card is located in slot A17. Located on the cards are two dip switches. S1 (upper lefthand corner) is the address select switch. The switch poles designated 1 through 5 correspond to DIO 1 through 5 for selection of instrument listen and talk address. The first 5 bits of the listen and talk address are the same in the Model 505. What differentiates the talk address and listen address is bits 6 and 7 which is sent 10 (TAG) or 01 (LAG). Address is selected by setting the appropriate switch open (non +) for true and closed for (+) for false. Any combination may be used except all true (11111) which is reserved for the universal command unlisten or untalk.

The other switch S2 (located at the bottom of the board) is used for parallel polling. Only one switch is allowed to be closed and any one of eight may be closed. Switch poles 1 through 8 correspond to D101 through D108. If parallel polling is not used, leave all switches open (non + position).

Transmission of data is based on the ASCII code for programming the 505 and for data output from the 505. The only exception to this is the command codes to program the IEEE interface card for mode of operation.

3.8.3 Formating the IEEE Card

To listen:

1. The controller must send ATN true
2. Send LAD (listen address)
3. Set ATN false
4. Send ASCII program (DAB 1-n)

(Example) RA170050
AP0011+0
BP0111+1
AM00P99P
etc.

IFC or unlisten (0111111) will remove the 505 from listening to the bus.

3.8.4 To Talk:

1. The controller must send ATN true
2. Send TAD (talk address)
3. Set ATN false
4. The Model 505 will send data back in ASCII format starting with the MSB and ending with the LSB (in conjunction with EOI) according to 3-wire handshake.

Note: the MSB character is the status bit to inform the controller the validity of the data to follow. The data of the first character is as follows.

- @ - valid data
- A - measurement in progress
- B - overrange (followed by units of measurement in data field deleted to a "space" character)
- C - MIP, OR combine
- D - Search overrange
- E - MIP, SOR combine
- F - MIP, OR, SOR combine

3.8.5 Service Request; Serial Polling

At the end of a measurement the 505 will issue a SRQ (service request). This status bit will remain true until it has undergone serial polling. The instrument will not issue another SRQ until after it is allowed to talk. Serial polling is performed as follows.

1. Instrument (any) issues SRQ true
2. Controller sends ATN SPE (serial poll enable)
3. Controller issues first instrument talk address (and ATN)
4. Controller releases ATN, and becomes listener

5. If talker wishes service then it releases SRQ bit and issues D107 (RSQ)
6. If SRQ bit is still true then another instrument also wishes service
7. Controller polls until it finds all the instruments who need service
8. Controller issues ATN SPD (serial poll disable)
9. Polling ends

3.8.6 Parallel Polling

Parallel polling is not a handshake process. It works independent of DAV, NRFD, and NDAC. Parallel polling is enabled by sending ATN EOI. If the 505 wishes to talk, then it will issue a true statement on one of eight DIO lines assigned to it by dip switch S2 on A17 board. The 505 should be assigned to only one DIO line. If parallel polling is not used, then the switch S2 should all (poles) be left open.

3.8.7 Device Trigger

The 505 can be requested to make a measurement by the IEEE command GET (group executive trigger) instead of the mnemonic character "GO". It is performed as follows:

1. Controller sends ATN MLA (my listen address)
2. Controller sends ATN GET (group executive trigger)
3. IFC (interface clear)